

SSSC NATIONAL INTER-SCHOOL SAILING CHAMPIONSHIPS 2010

SAILING INSTRUCTIONS

1 Rules

- 1.1 The events will be governed by the International Sailing Federation (ISAF) Racing Rules of Sailing (RRS) 2009-2012, the class rules of the respective classes, the Notice of Race, these Sailing Instructions and the Rules and Regulations of the SSSC/SPSSC.
- 1.2 Rule 70.5(b) will apply.

2 Identification

Primary Optimist Girls – To tie a red ribbon on the top end of the sprit
Byte Girls – To tie a red ribbon on the top end of the mast
Participants will collect the ribbons when they sign-on for the race.
The ribbons should be returned when they sign-off after the last race.

3 Notice To Competitors

- 3.1 Sailing Instructions and all notices to competitors will be posted on the Official Notice Board at National Sailing Centre.
- 3.2 There will be a skippers' briefing at 0900 hrs at the Multi-purpose Hall in the National Sailing Centre on 20, 21, 22 & 23 April 2010.

4 Changes In Sailing Instructions

Any change in sailing instructions will be posted before 0845 hrs on the day it will take effect, except that any change in the schedule of the races will be posted by 1730 hrs on the day before it will take effect.

5 Signals Made Ashore

Code flag AP, "Answering Pennant", with two sound signals (one sound signal when lowered) flown at the official flag post in the boatyard of the National Sailing Centre means that all races are postponed. When Code flag AP, "Answering Pennant", with two sound signals (one sound signal when lowered) is flown over a race area flag, only classes that are racing in that area are postponed. The warning signal will be made not less than 30 minutes after the AP is lowered.

6

Schedule Of Races

The schedule of races is as follows:

Date	Class	Race Area	Course	Warning Signal for 1 st Start
20 & 21 April 2010	Optimist – Senior Girls & C Girls	B	1	1000 hr
	Optimist – Senior Boys & C Boys		2	
	Byte – C Girls	C	1	
	Byte – C Boys		2	
	Laser – A Boys	A	1	
	420 – A Boys		2	

Date	Class	Race Area	Course	Warning Signal for 1 st Start
22 & 23 April 2010	Optimist – Junior Girls	B	1	1000 hr
	Optimist – Junior Boys		2	
	Byte – B Girls	C	1	
	Byte – B Boys		2	
	Laser – A Girls	A	1	
	420 – A Girls		2	

6.2 Max of 7 races to be sailed for all classes.

There is no limit to the number of races to be sailed each day.

If, 1 to 3 races are sailed, all races to count.

If, 4 to 7 races are sailed, one discard.

6.3 Flag H will be flown from the finishing boat to indicate that the last race of the day is being sailed.**6.4** On the final day (23 April 2010), no start shall be made after 1430 hrs.

7

Courses

Trapezoid Courses (Course 1 & 2) – for all classes.

Course 1 – Start, Marks: 1,2,3,2,3, Finish



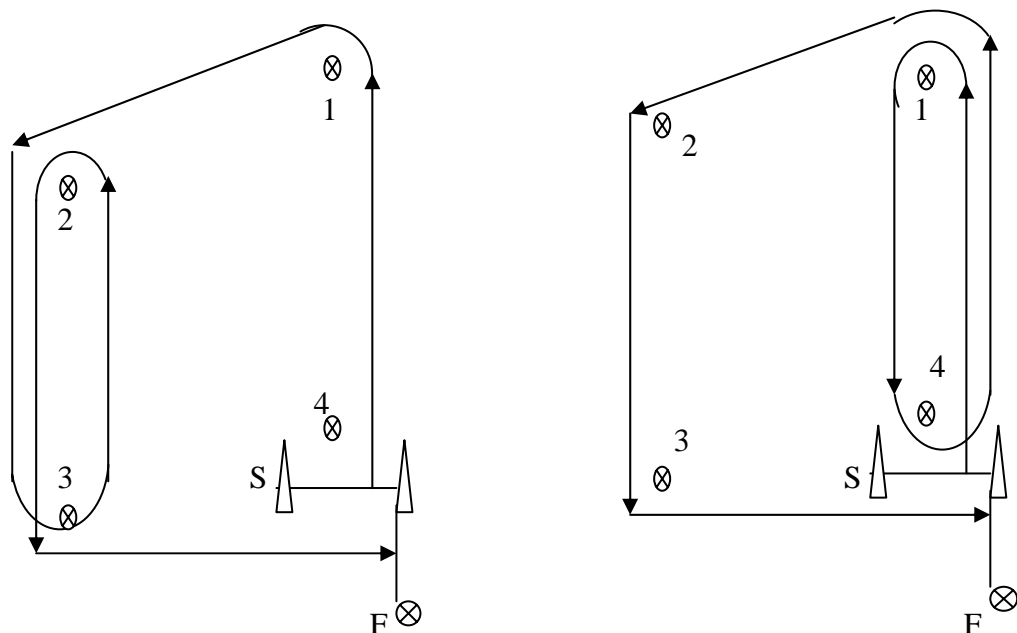

Course 2 – Start, Marks: 1,4,1,2,3, Finish



Above diagrams are approximate only.





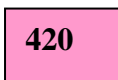
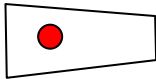
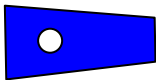
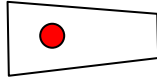
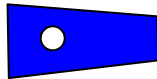

8

Flag Signals

Committee Boat	Race Areas' Flags 'A'/'B'/'C'	 Black letter on light orange cloth	 Black letter on light orange cloth	 Black letter on light orange cloth
Laser	Flag 'LSR'	 Black letter on light blue cloth		
420	Flag '420'	 Black number on light pink cloth		
Optimist (Girls)	Flag Numeral Pennant 1			
Optimist (Boys)	Flag Numeral Pennant 2			
Byte (Girls)	Flag Numeral Pennant 1			
Byte (Boys)	Flag Numeral Pennant 2			

9 **Race Areas**

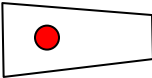
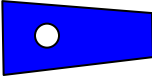
There will be 3 race areas. The race areas will be identified by their respective Area Flags which shall be flown from their respective committee boats. The race areas and classes sailed are as follows:

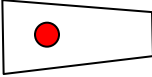
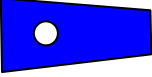
Race Area Flag	Class Start Order (Flag)	Race Area
Alpha  Marks 1, 2, 3, 4 are spherical pink	Laser  420 	Waters in front of NSRCC
Bravo  Marks 1, 2, 3, 4 are spherical yellow	Optimist (Girls)  Optimist (Boys) 	Waters in front of National Sailing Centre
Charlie  Marks 1, 2, 3, 4 are spherical pink	Byte (Girls)  Byte (Boys) 	Waters in front of PA East Coast Sea Sports Club

10 **Sign-On / Sign-Off**

- 10.1 Competitor shall personally sign-on for the racing before leaving the shore for any race or racing period and shall personally sign-off from racing upon returning to shore or retiring from the race or racing period at the National Sailing Centre.
- 10.2 Failure to comply with SI 10.1 will result in disqualification from the race. If more than one race is sailed in a day, failure to sign-on will result in disqualification from the first race of the day and failure to sign-off will result in the disqualification from the last race of the day. Failure to sign-on and sign-off will result in disqualification from all races of that day. The signing off period will end one hour after the completion of the last race of the respective race area. The Organising Committee, at its discretion, may extend the time permitted to sign off.

11 **Starting Line**

The Starting Line will be between the staff displaying the **area flag** on the committee boat and the staff displaying an **orange flag** on a boat at the port end.

12 **Finishing line**

The Finishing Line will be between the staff displaying a **blue flag** on the committee boat and a **spherical BLUE mark** at the starboard end.

13 **The Start**

13.1 Races will be started using Rule 26 with the following signals. Times will be taken from the visual signals; the absence of a sound signal shall be disregarded.

Signal	Flag and Sound	Minutes before the starting signal
Warning	Class flag, 1 sound	5
Preparatory	P, I or black flag, 1 sound	4
	P, I or black flag removed, 1 long sound	1
Starting	Class flag removed, 1 sound	0

The warning signal for each succeeding class shall be made with or after the starting signal of the preceding class.

13.2 The class sailing 'Course 1' will start first.
The class sailing 'Course 2' will start next.

13.3 Boats whose warning signal has not been made shall keep clear and be at least 50 metres away from the starting area. Failure to do so may incur a protest from the Race Committee.

13.4 A boat starting later than 4 minutes after her starting signal will be scored DNS.
This changes rule A4.1

14 **Recalls**

Individual recalls will be signaled in accordance with Rule 29.1.
General recalls will be signaled in accordance with Rule 29.2.

15 **Shortening Or Abandoning After The Start**

Courses may be shortened or abandoned at any rounding mark in accordance with Rule 32.

16 **Change Of The Next Leg Of The Course**

To change the next leg of the course, the race committee will lay a new mark – white spherical buoy (or the finishing line) and remove the original mark as soon as practical. When in a subsequent change a new mark is replaced, it will be replaced by an original mark.

17 **Penalties For Breaking Rules Of Part 2**

Taking a Penalty and The Two-Turns Penalty, Rules 44.1, 44.2, will apply.

18 **Appendix P Shall Apply**

19 **Time Limit**

The time limit for each race will be 1 hour 20 minutes for the leading boat. Boats finishing more than 20 minutes after the leading boat has finished, will be scored "DNF" (Did Not Finish). This changes Rules 35 and A4.

20 **Protests And Requests For Redress**

Protests shall be written on forms available at the Race Secretariat and lodged within 1 hour after the return of the Committee Boat from the race area. Protests must be submitted by the **teacher-in-charge** of the sailor/s. Any other form of protests will not be heard.

- 20.1 In addition to the requirements of RRS, a boat wishing to protest against another for breaches of Part 2, shall as soon as possible after finishing, sail alongside the finishing committee boat and inform them of her intention to protest, stating the sail number of the boat/s she intends to protest. At the same time, she should not interfere with other boats that are finishing. (This alters rule 61.1(a)).
- 20.2 Notices will be posted within 30 minutes of the protest time limit to inform competitors of hearings in which they are parties or names as witnesses. Hearing will be held in the Class Room, 2nd Floor, National Sailing Centre.
- 20.3 Notices of protest by the race committee or protest committee will be posted to inform boats under rule 61.1(b).
- 20.4 A list of boats that, under SI 18, have acknowledged breaking rule 42 or have been disqualified by the protest committee will be posted before protest time limit.
- 20.5 On the last day of the event a request for reopening a hearing shall be delivered
(a) within the protest time limit if the party requesting reopening was informed of the decision on the previous day.
(b) no later than 10 minutes after the party requesting reopening was informed of the decision on that day.
- 20.6 Decisions of the protest committee shall be final as provided in rule 70.5(b).
- 20.7 An amount of \$30.00 must accompany the protest form. The protest fee will not be refunded if the protest is ruled invalid or deemed frivolous.

21 **Scoring**

The Low Point System, Appendix A, shall apply. For number of discard, please refer to SI 6.2.

22 **Ties**

Individual score ties will be broken in accordance to Rule A8, Appendix A.

23 **Dispensation For Advertising And Sail Numbers**

- 23.1 Dispensation is granted to all original sails with commercial advertising and school/club initials.
- 23.2 Dispensation is also granted to original sails using letters instead of numbers.
- 23.3 Dispensation is also granted to boats loaned from MOESSC.
- 23.4 No two boats in the same event shall have the same sail identification. Only the first entry shall be accepted, all others shall be rejected.

- 23.5 Any request for change in sail number (with reasons) must be made on the official form and submitted to the Secretariat before signing out. Permission for change of sail number will be at the discretion of the Organising Committee.
- 24 **Replacement Of Crew**
- 24.1 Substitution of competitors will not be allowed.
- 24.2 Any request for change of equipment (with reasons) must be made on the official form and submitted to the Secretariat before signing out. Permission for change of equipment will be at the discretion of the Organising Committee.
- 25 **Safety Requirements**
- 25.1 All sailors must wear approved buoyancy aids **at all times whilst afloat**. Wet suits and jackets which require manual inflation are not deemed to be approved buoyancy aids.
- 25.2 A boat that retires from the race shall notify the race committee as soon as possible.
- 26 **Safety Precautions**
- Any competitor who is found to be unable to handle his/her boat safely shall be informed by the on-the-water judges or the safety officer to return to shore. The protest committee may at their discretion allow such competitors to participate in subsequent races when weather conditions improve.
- 27 **Division Championships (Primary School)**
- 27.1 Division Championship Plaques will be awarded if there is a minimum of 3 schools that can form a team with at least 3 sailors:
Senior Boys Champion, Senior Girls Champion, Junior Boys Champion and Junior Girls Champion.
- 27.2 The sum of the best three overall individual positions from each school will be used to decide the winning team.
- 27.3 In the event of a tie, the schools with the most number of top **individual** positions, starting with the number of firsts, then seconds and so on, shall be declared the winner.
- 28 **Division Championships (Secondary Schools / JCs / CIs)**
- 28.1 Division Championship Plaques will be awarded if there is a minimum of 3 schools that can form a team with at least 3 sailors:
A Division Boys, A Division Girls, B Division Boys, B Division Girls, C Division Boys and C Division Girls.
- 28.2 The sum of the best three overall individual positions / best combination of points scored (A and C Division, as explained in NOR) from each school will be used to decide the winning teams.
- 28.3 In the event of a tie, the school with, the most number of top **individual** positions, starting with the number of firsts, then seconds and so on / highest points scored, shall be declared the winner.

29 **Teacher(s)-In-Charge Of Teams**

29.1 Each participating team must be accompanied by the teacher(s)-in-charge who shall remain with the team throughout the competition.

29.2 Failure to comply with this rule may lead to the disqualification of the team(s) concerned.

29.3 The teacher-in-charge is also responsible for ensuring that the students under his/her charge sign-on for racing before leaving the shore for any race or racing period, and sign-off from racing upon returning to shore or retiring from the race or racing period.

30 **External Instructors / Coaches / Parents**

30.1 Support and coach boats shall keep clear and be at least 100 metres outside of the course area, while racing is on. Failure to do so may result in the Race Committee protesting the sailors of the supporters / coach. Penalty for this breach may be disqualification of one or more of the supporter's/coach's team. This changes Rule 60.2.

30.2 External instructors/coaches/parents shall not interfere with the running of the competitions or to question the decision(s) of the officials on duty.

30.3 The school(s) engaging the services of these external instructors/coaches/parents shall be held responsible for their conduct at the championships.

30.4 The names of the school/s' coaches should be registered with the secretariat at least 1 hour before the scheduled start of the first day of the championships.

30.5 Team's support/coach boats should be registered with the secretariat at least 1 hour before the scheduled start of the first day of the championships.

31 **Prize Presentation**

All prizes will be presented on **Friday, 23 April 2010**, at approximately **5.00pm** at the National Sailing Centre Multi-purpose Hall. Participating schools are requested to bring their school flags for the prize presentation. Participating schools are also encouraged to bring their supporters to the prize presentation.

32 **Disclaimer Of Liability**

Competitors participate in the event entirely at their own risk. See rule 4, Decision to Race. The organizing authority will not accept any liability for material damage or personal injury or death sustained in conjunction with or prior to, during, or after the event.

These sailing instructions will also be available at the following websites:

Singapore Sports School website (<http://www.sportsschool.edu.sg>)

Hougang Primary School website (<http://www.hougangpri.moe.edu.sg>)

Singapore Sailing Federation website (<http://www.sailing.org.sg>)